



VRLA Rechargeable Battery

BP7-12



FEATURES

- Maintenance free(no water topping-up required)
- No free acid(Non-spillable battery)
- Can be used in any orientation(excluding used inverted)
- Absorbent Glass Mat technology for efficient gas recombination
- Its design life is up to 8 years in floating application

APPLICATIONS

- UPS
- Laboratory Equipment
- Power Packs
- Toy-Cars
- Fishing Lights

SPECIFICATIONS

Nominal Voltage	12V	
Nominal Capacity	20 Hour Rate (350mA, 10.5V)	7.00 Ah
	10 Hour Rate (665mA, 10.5V)	6.65 Ah
	5 Hour Rate (1190mA, 10.5V)	5.95 Ah
	1 Hour Rate (4200mA, 9.30V)	4.20 Ah
Approx. Weight	2540g(5.60lbs.)	
Terminals	T2 (Faston Tab 250) T1 is optional	
Max. Discharge Current	105 A (5 sec.)	
Max. Charge Current	2.1 A	
Operating Temperature Range	Charge	0°C~40°C(32°F~104°F)
	Discharge	-20°C~50°C(-4°F~122°F)
	Storage	-20°C~40°C(-4°F~104°F)
Self Discharge	< 3% per month (25°C)	
Internal Resistance	≤25mΩ (Fully Charged)	



CONTAINER MATERIAL

- Standard: ABS(UL94 HB)
Model Name: BP7-12
- Optional: Flame Retardant ABS (UL94 V-0)
Model Name: BP7-12FR

Certificate as below:



MH19884

Compliance of the standards as below:

- IEC 61056-1
- JIS C 8702-1
- GB/T 19639.1
- VdS G100077

OUTER DIMENSIONS mm(inch)

Length (L)	Width (W)	Container Height (H)	Total Height (TH)
151±1.5(5.94±0.06)	65±1.5(2.56±0.06)	93±1.5(3.66±0.06)	98±2.0(3.86±0.08)

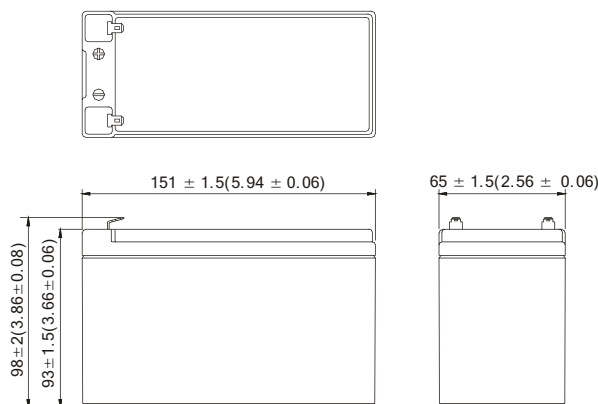

TERMINAL TYPE

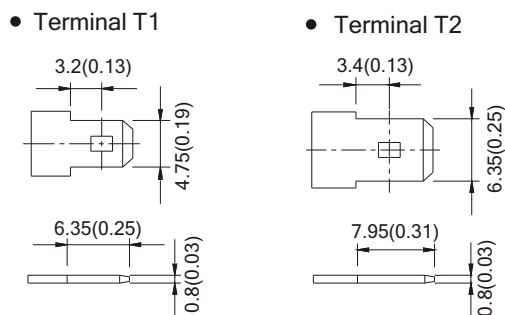

BP7-12 (BP7-12FR) discharge characteristics (25°C/77°F)

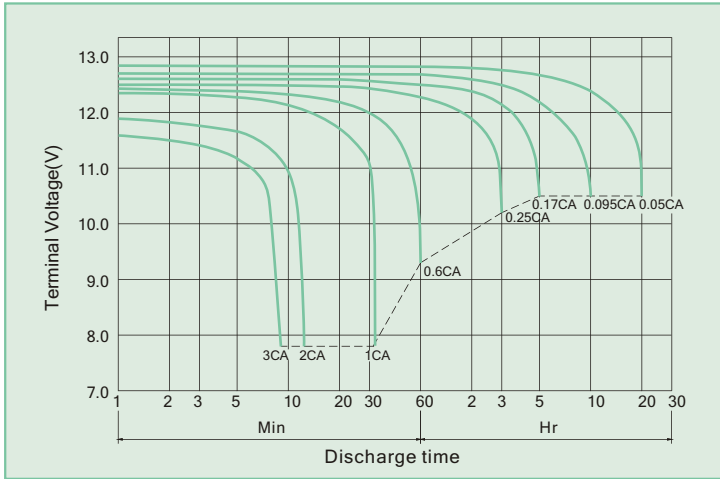

Battery Charging Characteristics

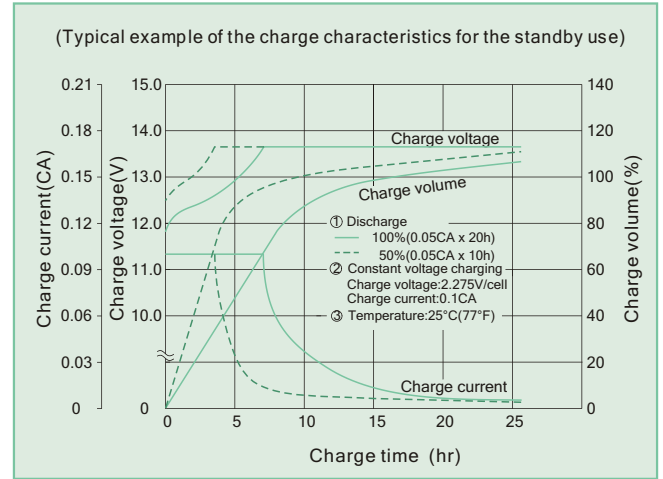

Charging Procedure

Application	Charging method	Charging Voltage at 25°C (V/cell)	Temperature compensation coefficient of charging voltage (mV/°C/cell)	Max. charging current (CA)	Charging time 0.1CA, 25°C (h)		Temp (°C)
					100% discharge	50% discharge	
For standby power Source	Constant voltage & Constant current charging (with current restriction)	2.25~2.30	-3	0.3	24	20	0~40 (32~104°F)
For cycle service		2.40~2.50	-4	0.3	16	10	

Effect Of Temperature On Long Term Float Life

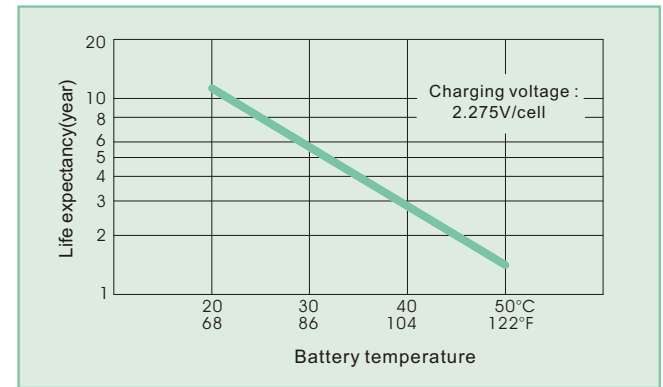

Constant power discharge characteristics at 25 °C/77 °F Unit: W

F.V. (V/cell) \ Discharge Time	5 Min	10 Min	15 Min	30 Min	1 Hr	3 Hr	5 Hr	10 Hr	20 Hr
1.80V	253	186	149	88.8	50.9	20.40	14.07	7.86	4.14
1.75V	293	202	156	92.2	52.5	20.81	14.28	7.98	4.20
1.70V	311	209	161	94.3	53.4	21.00	14.36	8.02	4.22
1.65V	325	214	165	95.6	54.1	21.15	14.41	8.04	4.24
1.60V	336	218	168	96.6	54.6	21.27	14.45	8.04	4.24

Constant current discharge characteristics at 25 °C/77 °F Unit: A

F.V. (V/cell) \ Discharge Time	5 Min	10 Min	15 Min	30 Min	1 Hr	3 Hr	5 Hr	10 Hr	20 Hr
1.80V	22.8	16.4	13.0	7.53	4.28	1.70	1.172	0.655	0.345
1.75V	26.9	17.8	13.6	7.81	4.41	1.73	1.190	0.665	0.350
1.70V	28.6	18.4	14.0	7.99	4.49	1.75	1.196	0.668	0.352
1.65V	29.8	18.8	14.3	8.11	4.54	1.76	1.201	0.670	0.353
1.60V	30.8	19.2	14.6	8.19	4.59	1.77	1.204	0.670	0.353

All data and artworks shall be changed without prior notice, BB reserves the right to explain and update the information contained herein.

B/2 REV. Mar. 2021

<p>USA: B&B BATTERY(USA) INC. 6415 RANDOLPH ST.COMMERCE,CA,90040 U.S.A. TEL:1-323-278-1900.1-800-278-8599 FAX:1-323-278-1268 E-Mail:sales@bb-battery.com</p> <p>CHINA FACTORY: B.B. TECH(CHANGSHA) CO., LTD. No.57 DongsiRoad, Changsha National Economic & Technical Development Zone, Changsha, Hunan PRC TEL:86-731-82955888 FAX:86-731-82955111 E-Mail:maggy@bb-battery.com</p>	<p>EUROPE: B&B BATTERY(EUROPE) B.V. SUITE 8, HAAKSBERGWEG 33, 1101 BP AMSTERDAM,THE NETHERLANDS TEL: 31-30-320-0190 MOBILE: 852-9128-2711 E-Mail: dliu@bb-battery.com</p> <p>HONG KONG: B&B BATTERY(Hong Kong) Co. TEL:852-2311-4918 FAX:852-2739-1182 E-Mail:bbhk@hkstar.com</p>	<p>JAPAN: B&B BATTERY(JAPAN) CO., LTD. 1375-11 NARAHARA-MACHI,HACHIOJI, TOKYO 193-0803,JAPAN. TEL:81-426-25-6375 FAX:81-426-25-6375 E-Mail:miyata@bb-battery.com</p> <p>TAIWAN: B.B. BATTERY(TAIWAN) CO., LTD. TEL:886-6-502-5150 FAX:886-6-589-8087 E-Mail:kevinlin@bb-battery.com</p>
---	---	---