

VRLA Rechargeable Battery

SHR7-12

FEATURES

- Maintenance free(no water topping-up required)
- No free acid(Non-spillable battery)
- Can be used in any orientation(excluding used inverted)
- The battery is designed for high rate usage
- Its design life is up to 5 years in floating application
- Absorbent Glass Mat technology for efficient gas recombination
- The power density at 2 min~15min discharging rate is 50% higher than BP series

APPLICATIONS

- UPS
- Emergency Lights
- Toy-Cars
- Fishing Lights
- Power Packs

SPECIFICATIONS

Nominal Voltage	12V	
Nominal Capacity	10 Hour Rate (0.58 A, 1.75V/Cell)	5.8 Ah
	15 Min Rate (27W, 1.60V/Cell)	3.375 Ah
Approx. Weight	1840g(4.06lbs.)	
Terminals	T2 (Faston Tab 250) T1 is optional	
Max. Discharge Current	90 A (5 sec.)	
Max. Charge Current	1.80 A	
Operating Temperature Range	Charge	0°C~40°C(32°F~104°F)
	Discharge	-20°C~50°C(-4°F~122°F)
	Storage	-20°C~40°C(-4°F~104°F)
Self Discharge	< 3% per month (25°C)	
Internal Resistance	≤ 20mΩ (Fully Charged)	



CONTAINER MATERIAL

- Standard:ABS(UL94 HB)
Model Name: SHR7-12
- Optional: Flame Retardant ABS (UL94 V-0)
Model Name:SHR7-12FR

Certificate as below:



Compliance of the standards as below:

- IEC 61056-1
- JIS C 8702-1
- GB/T 19639.1

OUTER DIMENSIONS

mm(inch)

Length (L)	Width (W)	Container Height (H)	Total Height (TH)
90±1.5(3.54±0.06)	70±1.5(2.76±0.06)	102±1.5(4.02±0.06)	106±2.0(4.17±0.08)

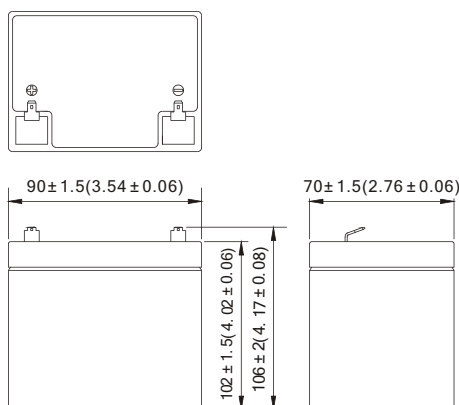

TERMINAL TYPE

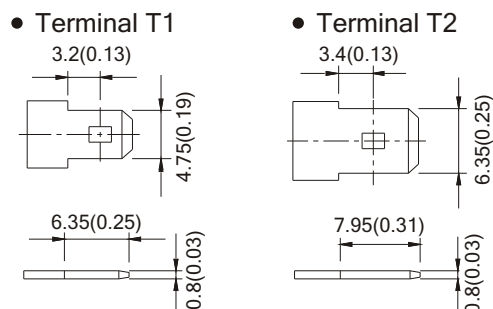

SHR7-12 (SHR7-12FR) discharge characteristics (25°C/77°F)

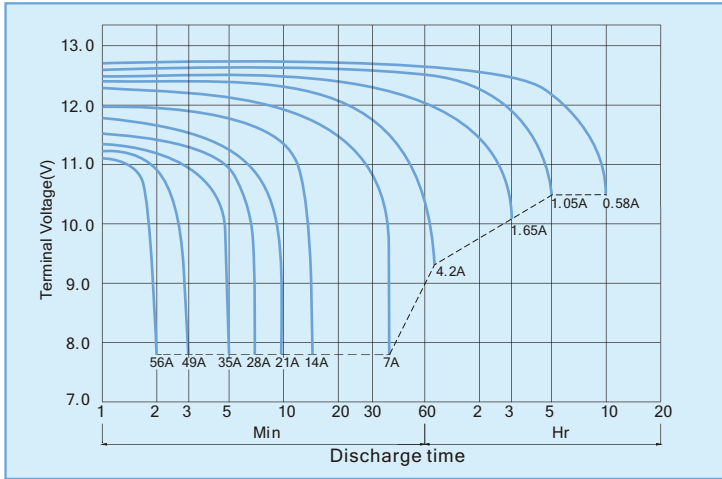

Battery Charging Characteristics

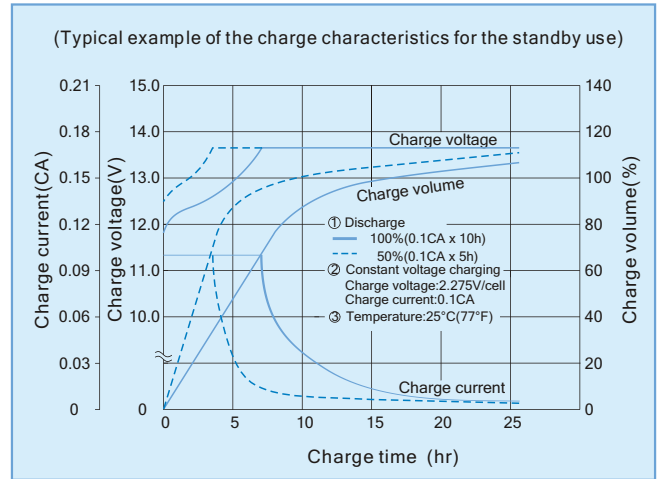

Charging Procedure

Application	Charging method	Charging Voltage at 25°C (V/cell)	Temperature compensation coefficient of charging voltage (mV/°C/cell)	Max. charging current (A)	Charging time 0.1CA, 25°C (h)		Temp (°C)
					100% discharge	50% discharge	
For standby power Source	Constant voltage & Constant current charging (with current restriction)	2.25~2.30	-3	1.8	24	20	0~40 (32~104°F)
For cycle service		2.40~2.50	-4	1.8	16	10	

Effect Of Temperature On Long Term Float Life

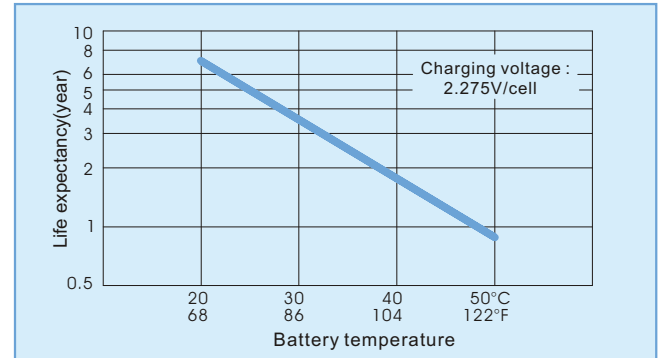

Constant power discharge characteristics at 25 °C/77 °F Unit: W

F.V. (V/cell) \ Discharge Time	2 Min	3 Min	5 Min	10 Min	15 Min	20 Min	30 Min	40 Min	50 Min	60 Min	120 Min
1.80V	484	408	307	196	153	119	88.4	68.7	58.3	51.4	27.5
1.75V	519	438	330	208	157	122	90.4	70.6	59.9	52.1	27.9
1.70V	545	459	343	212	159	124	91.3	71.4	60.4	52.4	28.1
1.67V	557	473	355	217	161	125	92.1	72.2	60.9	52.6	28.3
1.60V	568	486	368	221	162	126	92.9	73.0	61.3	52.8	28.5
1.50V	579	496	372	224	163	127	93.7	73.8	62.0	53.0	28.7

Constant current discharge characteristics at 25 °C/77 °F Unit: A

F.V. (V/cell) \ Discharge Time	2 Min	3 Min	5 Min	10 Min	15 Min	20 Min	30 Min	40 Min	50 Min	60 Min	120 Min
1.80V	44.5	37.4	27.6	17.1	13.2	10.17	7.50	5.83	4.91	4.31	2.29
1.75V	47.9	40.4	29.8	18.2	13.5	10.46	7.71	6.00	5.05	4.39	2.33
1.70V	50.5	42.4	31.0	18.7	13.7	10.62	7.78	6.07	5.09	4.41	2.34
1.67V	51.6	43.7	32.2	19.2	13.9	10.74	7.86	6.15	5.14	4.43	2.36
1.60V	52.7	44.9	33.4	19.5	14.1	10.85	7.93	6.22	5.18	4.45	2.38
1.50V	53.8	45.9	33.9	19.8	14.3	10.94	8.03	6.30	5.25	4.48	2.40

All data and artworks shall be changed without prior notice, BB reserves the right to explain and update the information contained herein.

C/3 REV. Jan. 2022

USA:
B&B BATTERY(USA) INC.
6415 RANDOLPH ST.COMMERCE, CA,90040 U.S.A.
TEL:1-323-278-1900.1-800-278-8599
FAX:1-323-278-1268
E-Mail:sales@bb-battery.com

CHINA FACTORY:
B.B. TECH(CHANGSHA) CO., LTD.
No.57 Dongsiroad, Changsha National Economic & Technical Development Zone, Changsha, Hunan PRC
TEL:86-731-82955888
FAX:86-731-82955111
E-Mail:maggy@bb-battery.com

EUROPE:
B&B BATTERY(EUROPE) B.V.
SUITE 8, HAAKSBERGWEG 33, 1101
BP AMSTERDAM, THE NETHERLANDS
TEL: 31-30-320-0190
MOBILE: 852-9128-2711
E-Mail: dliu@bb-battery.com

HONG KONG:
B&B BATTERY(Hong Kong) Co.
TEL:852-2311-4918
FAX:852-2739-1182
E-Mail:bbhk@hkstar.com

JAPAN:
B&B BATTERY(JAPAN) CO., LTD.
1375-11 NARAHARA-MACHI,HACHIOJI,
TOKYO 193-0803,JAPAN.
TEL:81-426-25-6375
FAX:81-426-25-6375
E-Mail:miyata@bb-battery.com

TAIWAN:
B.B. BATTERY(TAIWAN) CO., LTD.
TEL:886-6-502-5150
FAX:886-6-589-8087
E-Mail:kevinlin@bb-battery.com